



WP4SC400QT



JOB NAME: _____
 DATE: _____
 TYPE: _____

DESCRIPTION

RAB's largest wallpack for 400 watt floods. All aluminum precision die cast construction with tempered glass refractor. Lamp supplied.

SPECIFICATIONS

Finish:

Chip and fade resistant polyester powder coating.

Housing:

Die cast aluminum 1/2" NPS tapped holes top, both sides and back for conduit or photocontrol. Hinged refractor frame, Continuous silicone rubber gasket.

Reflector:

Specular anodized aluminum, removable for installation. Symmetrical light pattern maximizes distance between fixtures.

Refractor:

Prismatic optics designed to minimize glare and throw light down and out. Heat resistant borosilicate glass.

UL Listing:

Suitable for wet locations. HID fixtures can be wired with 90° C supply wiring if supply wires are routed 3" away from the ballast.

Patents:

RAB sensor and fixture designs are protected under U.S. and International Intellectual Property laws

Quad Tap:

Fixture works with 120, 208, 240 and 277 Volts

Color:

Bronze

Weight:

29.9

DIMENSIONS

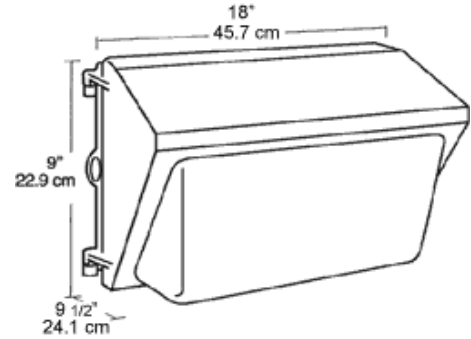

PHOTOMETRIC

250w HPS @ 16' Mounting Height

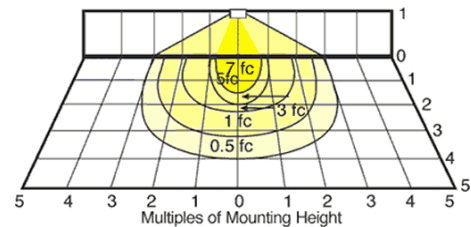

Mounting Height	Multiplier
8'	4
10'	2.6
12'	1.8
16'	1.0
20'	.6
24'	.5
32'	.3

Watts	Multiplier	HPS	vMH
200PS			.7
250	1.0		.7
250PS			.9
320PS			1.0
350PS			1.1
400	1.8		1.2
400PS			1.4

ORDERING INFORMATION

High Pressure Sodium
 Lamp supplied with fixture

Total Watts	Lamp Type	Lamp Base	Ballast
400	ED37	Mogul	CWA-HPF QT

Starting Amps/ Operating Amps
 120V 208V 240V 277V

Input Watts	LAMP ANSI	Initial Lumens	Lamp Hours
464	S51	50000	24000

Factory Installed Options
 Add suffix to Catalog Number

Tamperproof screws (/TP)
 Swivel Photocontrol (/PCS)
 Single fusing for 120 and 277 volt (/F)

Quartz Restrike (/QR)
 Double fusing for 208 and 240 volt (/FF)
 Button Photocontrol (/PC)

Note: Specifications may change without notice

480 volt only ballast (substitute /480 for QT)